

1100 hp (820 kW) @ 1600 rpm Marine Diesel Engine

S12R-Y3MPTAW-4



BEST-IN-CLASS FEATURES

EPA TIER III CERTIFIED	FOR MARINE PROPULSION WITH SIMPLE AND ROBUST MECHANICAL CONTROLS
LARGE DISPLACEMENT	BIG BORE ENGINE FOR HARD-WORKING BOATS. LOWER POWER DENSITY THAN OTHER MAJOR MANUFACTURERS ENSURES LESS STRESS ON THE COMPONENTS AND LONG, TROUBLE-FREE EQUIPMENT LIFE
EASY MAINTENANCE	NO COMPUTER NEEDED TO SERVICE THE SIMPLE AND ROBUST MECHANICAL CONTROLS. INDIVIDUAL CYLINDER HEADS AND CRANKSHAFT ACCESS PORTS ALLOW FOR A TRUE IN-FRAME OVERHAUL
RATING	MITSUBISHI RATING IS EQUIVALENT TO UNRESTRICTED CONTINUOUS RATINGS OFFERED IN NORTH AMERICA
LEGENDARY QUALITY	ENGINES ARE DESIGNED, MANUFACTURED AND TESTED IN JAPAN TO MEET THE QUALITY EXPECTATIONS OF THE DEMANDING JAPANESE MARKET

SPECIFICATIONS

COMBUSTION	-----	4-STROKE COMPRESSION IGNITION, 14.5:1 CR
DISPLACEMENT	-----	49 LITER, 12-CYLINDER VEE
BORE X STROKE	-----	170 X 180 MM (6.69 X 7.09 IN)
WEIGHT	-----	DRY 5320 KG (11731 LB) / WET 5600 KG (12348LB)
FLYWHEEL AND HOUSING	-----	SAE #00, 21-INCH, 193-TOOTH FLYWHEEL
ASPIRATION	-----	TURBOCHARGED, AFTERCOOLED
EXHAUST	-----	DRY MANIFOLD
COOLING	-----	DUAL-CIRCUIT, KEEL COOLED
OIL PAN CAPACITY	-----	200 LITER (53 US GAL)
LUBE OIL SYSTEM	-----	OIL COOLER, FULL FLOW + BYPASS OIL FILTER
FUEL SYSTEM	-----	MECHANICAL, 2 x PS6 INLINE PUMPS
GOVERNOR	-----	HYDRAULIC, WOODWARD PSG
STARTING SYSTEM	-----	24V, 2 X 7.5KW; OPTIONAL AIR START

STANDARD EQUIPMENT

COOLING:	HEAVY-DUTY JACKET WATER PUMP, OIL COOLER, THERMOSTATS
FUEL SYSTEM:	MECHANICAL FEED PUMP, FULL-FLOW FUEL FILTER
ELECTRICAL:	2 x 7.5KW STARTER, 35A ALTERNATOR, STOP SOLENOID, STARTER SAFETY RELAY
PTO:	1-GROOVE FRONT PTO PULLEY, UP TO 470kW (430 hp) DIRECT DRIVE FRONT TAKE-OFF
OTHER:	MATING FLANGES, SPARE MAINTENANCE PARTS AND TOOLS
OPTIONS:	AIR START, I/C PUMP KIT, DIGITAL DISPLAY WITH DATALOGGING, GAUGE PANELS

DISCLAIMER All information provided is believed to be correct but is not guaranteed and subject to change without notice

S12R-Y3MPTAW-4/ 1100 hp (820 kW) @ 1600 rpm

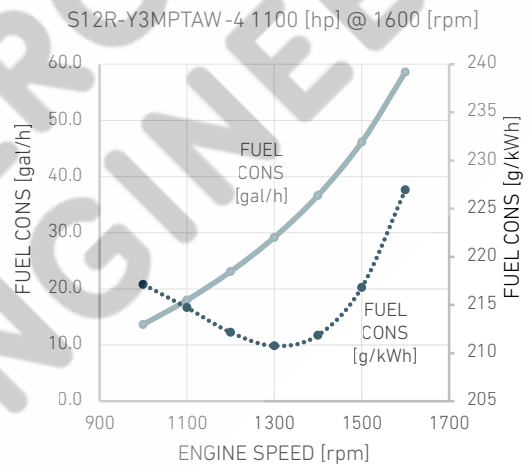
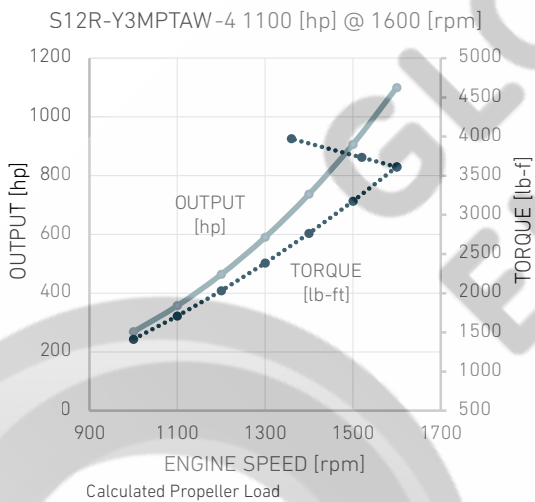
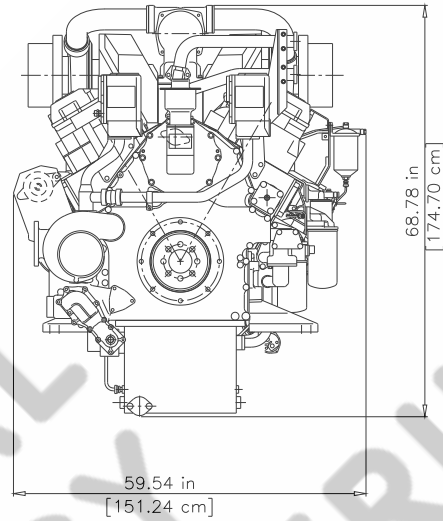
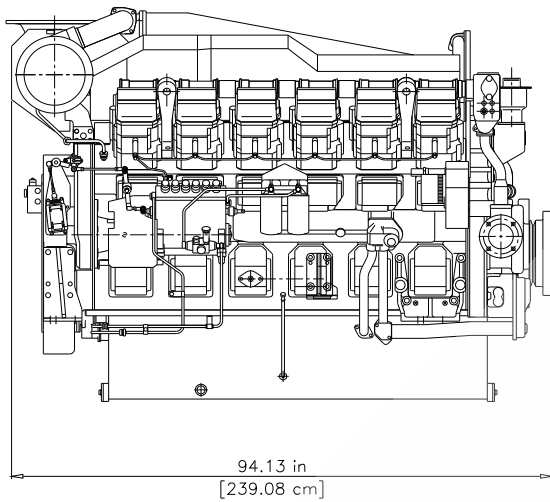

Fuel Consumption is based on ISO3046/1 with +5% tolerance at rated power and 0.8389 fuel specific gravity

S12R-Y3MPTAW-4 1100 [hp] @ 1600 [rpm]

LOAD	SPEED [rpm]	OUTPUT [hp]	TORQUE [lb-ft]
100%	1600	1100	3611
82%	1500	906	3174
67%	1400	737	2764
54%	1300	590	2384
42%	1200	464	2031
32%	1100	357	1707
24%	1000	269	1410

S12R-Y3MPTAW-4 1100 [hp] @ 1600 [rpm]

LOAD	SPEED [rpm]	FUEL CONS [gal/h]	FUEL CONS [l/h]
100%	1600	58.6	221.9
82%	1500	46.2	174.7
67%	1400	36.7	138.8
54%	1300	29.2	110.5
42%	1200	23.1	87.5
32%	1100	18.0	68.2
24%	1000	13.7	51.8
Average Fuel Consumption on ISO 8178 Cycle, Mode E3		38.6	146.3

DISCLAIMER: All information provided is believed to be correct but is not guaranteed and subject to change without notice.