

429hp (320 kW) @ 1940 rpm Marine Diesel Engine

S6B3-Y3MPTAW-2

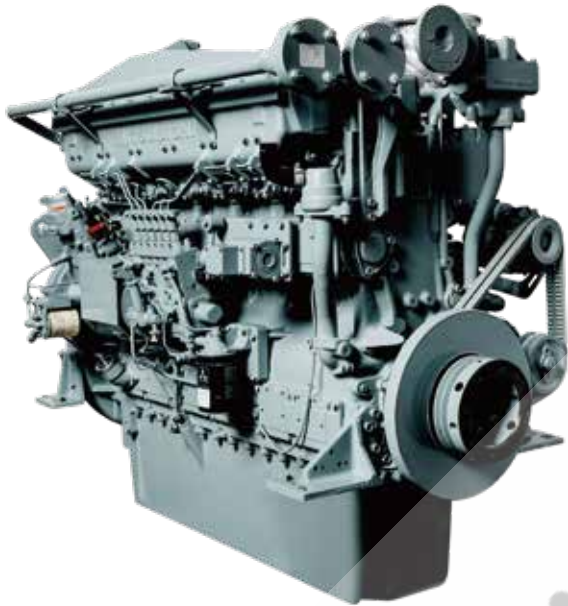

BEST-IN-CLASS FEATURES

EPA TIER III CERTIFIED	FOR MARINE PROPULSION WITH SIMPLE AND ROBUST MECHANICAL CONTROLS
LARGE DISPLACEMENT	FOR HARD-WORKING BOATS. 14 % MORE DISPLACEMENT THAN OTHER MAJOR MANUFACTURERS ENSURES LESS STRESS ON THE COMPONENTS AND LONG, TROUBLE-FREE EQUIPMENT LIFE
EASY MAINTENANCE	NO COMPUTER NEEDED TO SERVICE THE SIMPLE AND ROBUST MECHANICAL CONTROLS. INDIVIDUAL CYLINDER HEADS AND CRANKSHAFT ACCESS PORTS ALLOW FOR A TRUE IN-FRAME OVERHAUL
RATING	MITSUBISHI RATING IS EQUIVALENT TO HEAVY DUTY RATINGS OFFERED IN NORTH AMERICA
LEGENDARY QUALITY	ENGINES ARE DESIGNED, MANUFACTURED AND TESTED IN JAPAN TO MEET THE QUALITY EXPECTATIONS OF THE DEMANDING JAPANESE MARKET

SPECIFICATIONS

COMBUSTION	4-STROKE COMPRESSION IGNITION, 15:1 CR
DISPLACEMENT	14.6 LITER, 6-CYLINDER INLINE
BORE X STROKE	135 X 170 MM (5.31 X 6.69 IN)
WEIGHT	DRY 1310 KG (2889 LB) / WET 1407 KG (3102 LB)
FLYWHEEL AND HOUSING	SAE #1, 14-INCH, 143-TOOTH FLYWHEEL
ASPIRATION	TURBOCHARGED, AFTERCOOLED
EXHAUST	DRY MANIFOLD
COOLING	DUAL-CIRCUIT, KEEL COOLED
OIL PAN CAPACITY	70 LITER (18.5 US GAL)
LUBE OIL SYSTEM	OIL COOLER, FULL FLOW + BYPASS OIL FILTER
FUEL SYSTEM	MECHANICAL, BOSCH S7S INLINE PUMP
GOVERNOR	HYDRAULIC, WOODWARD PSG
STARTING SYSTEM	24V, 6KW; OPTIONAL AIR START

STANDARD EQUIPMENT

COOLING:	HEAVY-DUTY JACKET WATER PUMP, OIL COOLER, THERMOSTATS
FUEL SYSTEM:	MECHANICAL FEED PUMP, FULL-FLOW FUEL FILTER
ELECTRICAL:	6KW STARTER, 35A ALTERNATOR, STOP SOLENOID, STARTER SAFETY RELAY
PTO:	2-GROOVE FRONT PTO PULLEY, UP TO 297kW (398 hp) DIRECT DRIVE FRONT TAKE-OFF
OTHER:	MATING FLANGES, SPARE MAINTENANCE PARTS AND TOOLS
OPTIONS:	AIR START, I/C PUMP KIT, DIGITAL DISPLAY WITH DATALOGGING, GAUGE PANELS

DISCLAIMER All information provided is believed to be correct but is not guaranteed and subject to change without notice

S6B3-Y3MPTAW-2/ 429 hp (320 kW) @ 1940 rpm

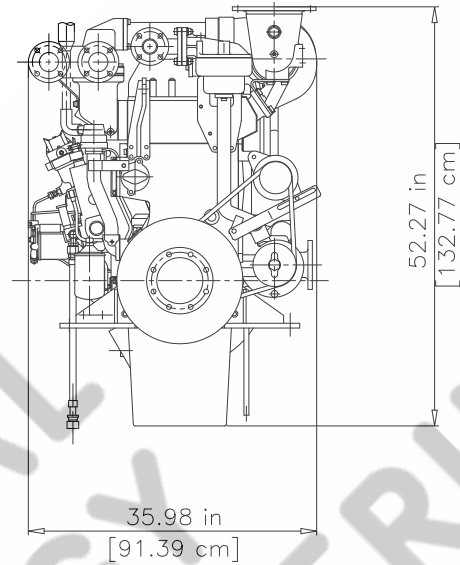
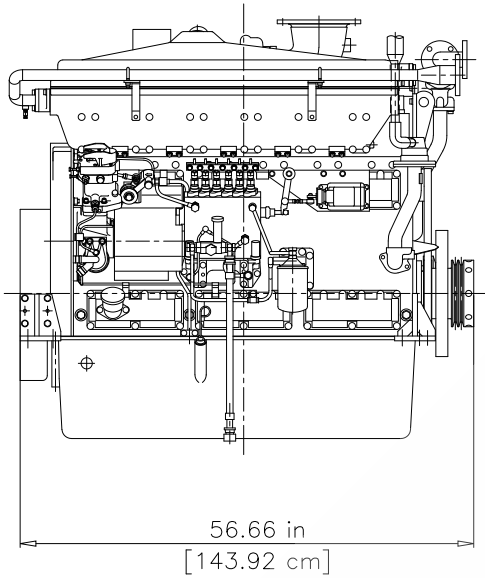

S6B3-Y3MPTAW-2 429 hp @ 1940 rpm

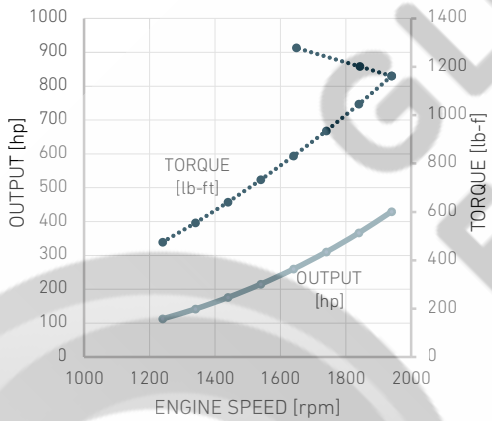

Calculated Propeller Load

S6B3-Y3MPTAW-2 429 hp @ 1940 rpm

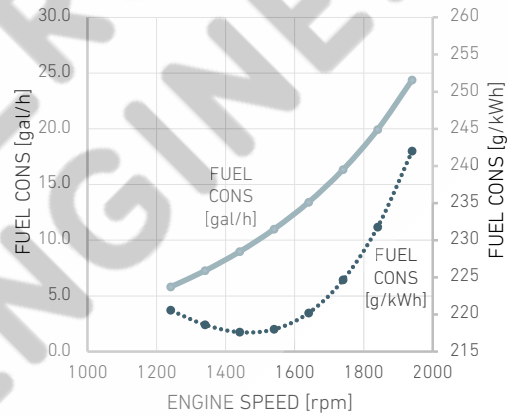

Fuel Consumption is based on ISO3046/1 with +5% tolerance at rated power and 0.8389 fuel specific gravity

S6B3-Y3MPTAW-2 429 [hp] @ 1940 [rpm]

LOAD	SPEED [rpm]	OUTPUT [hp]	TORQUE [lb-ft]
100%	1940	429	1161
85%	1840	366	1045
72%	1740	310	935
60%	1640	259	830
50%	1540	215	732
41%	1440	175	640
33%	1340	141	554
26%	1240	112	475

S6B3-Y3MPTAW-2 429 [hp] @ 1940 [rpm]

LOAD	SPEED [rpm]	FUEL CONS [gal/h]	FUEL CONS [l/h]
100%	1940	24.4	92.3
85%	1840	19.9	75.4
72%	1740	16.3	61.8
60%	1640	13.4	50.7
50%	1540	11.0	41.6
41%	1440	9.0	34.0
33%	1340	7.3	27.5
26%	1240	5.8	22.0
Average Fuel Consumption on ISO 8178 Cycle, Mode E3		15.9	60.2

DISCLAIMER: All information provided is believed to be correct but is not guaranteed and subject to change without notice.